

LUBRIQUIP[®]

Lubrication & Dispensing Solutions

Trabon[®] and *Manzel*[®]

MH Modular Divider Valves Product Specs and Ordering

***Modular, Series-
Progressive, Divider
Valve Delivers
Positive Oil
Lubrication for Gas
Engines,
Compressors and
Similar Equipment at
Pressures up to 6000
PSI and 7500 PSI***

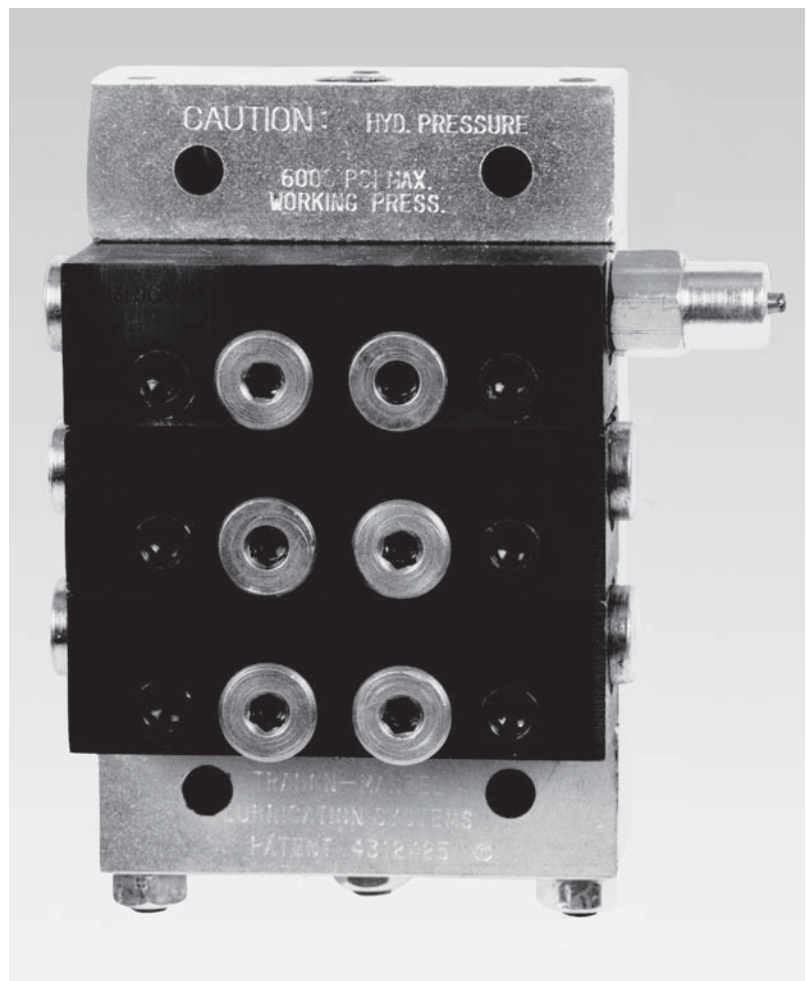

MH divider valves precisely proportion a volume of oil to satisfy the different requirements of every point in a lube system. They operate in sequential fashion to ensure that no point is missed. Series-Progressive design provides ready monitoring capability.

MH divider valves are available for use with petroleum or synthetic oils and at pressures up to 7500 PSI. The modular, stackable subplate design provides maximum application flexibility. Accessory components are available for visual diagnostics and electrical monitoring.

FEATURES/BENEFITS

- Use in terminating oil systems at pressures up to 7500 PSI (517 bar)
- Lubricate up to 16 points from one divider valve assembly.
- Soft-seal O-ring construction and indicator ports minimize leakage and reduce maintenance.
- Built-in check valves prevent lube back flow and help keep lube lines full.
- Stackable subplate design simplifies build-up, installation and maintenance.
- Ample clearance between outlet connections for elbows and 3/8" lube lines.
- Performance indicators, cycle indicators and proximity switches monitor divider valve action to simplify troubleshooting and repair.
- Choice of SAE or NPSF inlet and outlet connections.
- Choice of 70 Durometer Buna-N or 90 Durometer Viton O-rings.

DESCRIPTION

Each MH divider valve assembly incorporates from three to eight working piston sections (1), associated subplate sections which include the outlet distribution ports (2), an inlet section (3), and an end section (4).

“Twin” sections are ported to provide separate outputs from each end of a working piston and direct them to two lube points. “Single” sections are ported to combine the outputs from each end of a working piston and direct it to one lube point.

Crossport plates (5) may be installed between working piston sections and subplate sections to combine the

outputs of successive working piston sections. (Crossport plates must not be installed beneath bottom working sections.) Singling plates (6) may be installed to combine the outputs from both ends of a working piston in any “Twin” section. Bypass sections (not shown) may be used in place of working piston sections to eliminate inactive lube lines without disturbing active lube lines, or to provide for future system expansion. (Divider assembly must contain at least three working sections in addition to bypass section.)

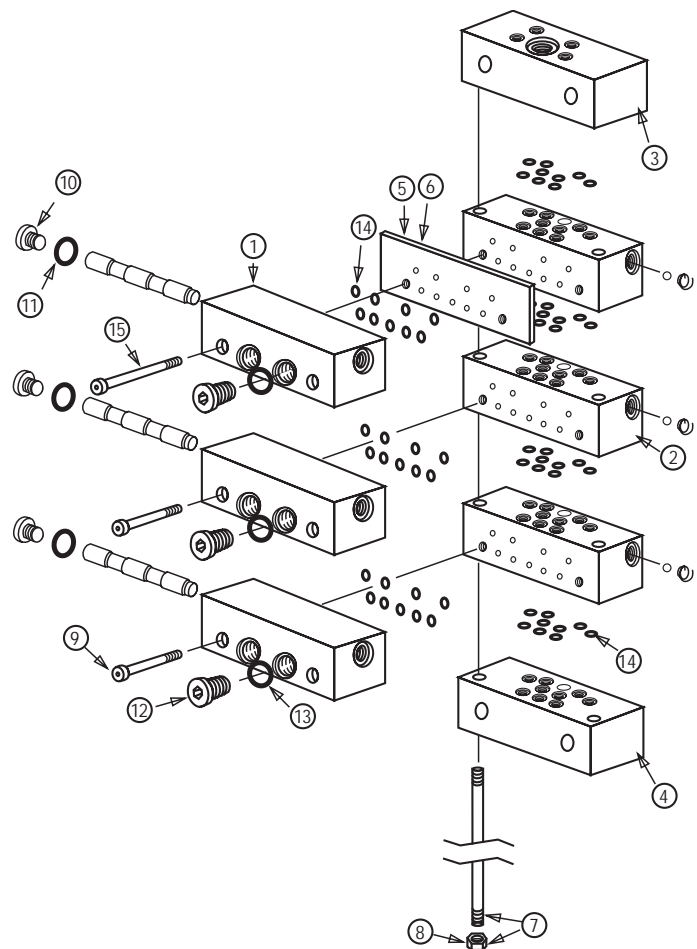

Components

Key	Size	Description	Output Volume		Working Section **	With/Cycle Pin ** Right-Hand Side	With/FSmech ** Prox. Switch Right-Hand Side
			in ³	cm ³			
1	6T	.006 Twin	0.006	0.098	106-000-085	N.A.	106-008-003
	6S	.006 Single	0.012	0.197	106-000-025	N.A.	106-008-000
	9T	.009 Twin	0.009	0.148	106-000-095	N.A.	106-008-004
	9S	.009 Single	0.018	0.295	106-000-035	N.A.	106-008-001
	12T	.012 Twin	0.012	0.197	106-000-105	N.A.	106-008-005
	12S	.012 Single	0.024	0.393	106-000-045	N.A.	106-008-002
	18T	.018 Twin	0.018	0.295	106-000-115	106-000-235	106-000-175
	18S	.018 Single	0.036	0.590	106-000-055	106-000-205	106-000-145
	24T	.024 Twin	0.024	0.393	106-000-125	106-000-245	106-000-185
	24S	.024 Single	0.048	0.787	106-000-065	106-000-215	106-000-155
	30T	.030 Twin	0.030	0.492	106-000-135	106-000-255	106-000-195
	30S	.030 Single	0.060	0.983	106-000-075	106-000-225	106-000-165
	-	-	Bypass	-	-	106-000-010	-

Key	Description	1/8-27 NPSF	7/16-20 SAE
2	Intermediate Subplate*	527-000-311	527-003-550
3	Inlet (w/Bleed)	1/4-18 NPSF 527-000-321	7/16-20 SAE 527-000-325
4	End Section*	527-001-900	
5	Crossport Plate-Right+#	527-005-320	
	Crossport Plate-Left+#	527-005-330	
	Crossport Plate-Both+#	527-005-340	
6	Singling Plate+#	527-005-350	

Parts List Key	Description	Part Number
7	Tie Rod & Nut Assembly (3 Req'd)	
	3 Section	527-001-930
	4 Section	527-001-940
	5 Section	527-001-950
	6 Section	527-001-960
	7 Section	527-001-970
	8 Section	527-001-980
	8	Tie Rod Nut Only
9	Valve Block Mounting Screw	419-140-070
10	Piston Enclosure Plug	527-000-232
11	Piston Enclosure "O" Ring (70 Buna)	422-210-040
	Piston Enclosure "O" Ring (90 Viton)	422-240-040
12	Indicator Port Plug	527-300-840
13	Indicator Port "O" Ring (70 Buna)	422-210-030
	Indicator Port "O" Ring (90 Viton)	422-240-030
14	(70 Duro) Buna-N "O" Ring	422-010-060
	(90 Duro) Viton "O" Ring	527-000-840
15	Valve Block Mounting Screw for use with Crossport and Singling Plates	419-140-080

* Part numbers include standard Buna-N 70 Durometer seals for 6000 PSI maximum system pressure. Consult Lubriquip for Viton 90 Durometer (7500 PSI) seals.

Working piston sections are also available with cycle indicators and field sensitive mechanical proximity switches mounted on the left-hand side.

When requested, crossporting and singling can be accomplished by using appropriate plates.

+ Part numbers include appropriate mounting screws.

Part numbers include 90 Durometer Viton seals for 7500 PSI maximum system pressure.

CYCLE INDICATORS

By sensing divider valve piston movement, lube volume can be accurately monitored and controlled. A variety of mechanical and electrical cycle indicators are available for this purpose.

TYPE	RATING	PART NO
S.P.D.T.	20A @ 125, 250 VAC .50A @ 125 VDC .25A @ 250 VDC	510-599-000
D.P.D.T.	10A @ 125, 250 VAC .30A @ 125 VDC .15A @ 250 VDC	510-577-000

DIVIDER VALVE SECTIONS WITH ATTACHED CYCLE INDICATOR PIN

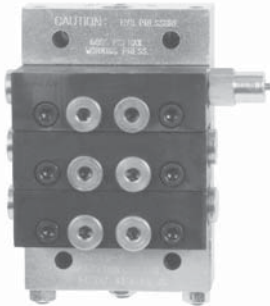

18 through 30 size MH divider valve sections are available with a factory-installed cycle indicator pin attached to either end of the piston. The pin moves in and out one time for each complete cycle of the divider valve assembly. Application pressure is limited to 3500 PSI.

See Page 3 for part numbers. Consult Lubriquip for part numbers of sections with pin on left-hand side and for part numbers of sections with viton seals.

CYCLE INDICATOR SWITCH - FOR USE WITH DIVIDER VALVE SECTION HAVING ATTACHED CYCLE INDICATOR PIN



Switch bracket clamps to a cycle indicator pin housing. Cycle indicator pin movement repeatedly trips an electrical (limit) switch. Switch pulses provide input to a system controller which counts them to control and verify completion of the lube cycle.

MAGNETIC VISUAL CYCLE INDICATOR



A No-Weep Magnetic Visual Cycle Indicator can be installed in place of a piston enclosure plug on any size divider valve section. Six steel balls in a transparent sleeve follow a magnet which moves with the cycling piston. Unlike a cycle indicator pin, working section displacement is not reduced. Suitable for application at pressures up to 7500 PSI. Part number 509-932-522.

UNIVERSAL CYCLE COUNTER - FOR USE WITH DIVIDER VALVE SECTION HAVING ATTACHED CYCLE INDICATOR PIN



Counter housing clamps to a cycle indicator pin housing. A 6-digit mechanical counter, advanced by the movement of a divider valve cycle indicator pin, provides visual assurance that the system is functioning. Every "count" indicates one complete cycle of the divider valve assembly. Suitable for application at pressures up to 3500 PSI. Part number 527-002-410

REED-TYPE PROXIMITY SWITCH (OPTIONAL)

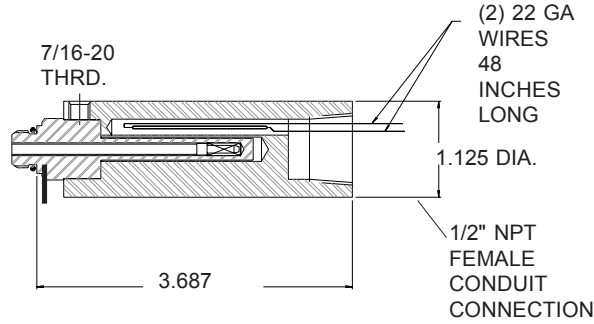

This magnetically operated SPST switch is installed in place of a piston enclosure plug. This "unattached pin" type switch can be used with any size MH working section

An indicator type magnet follows the divider valve piston, opening and closing the switch as it moves back and forth.

SPECIFICATIONS

- Material Stainless Steel, Aluminum
- Switch Rating 1.2 Volt-Amperes; up to 115VAC, 50VDC
- Contacts Single Pole, Single Throw
- Ambient Temperature Range 0°F to + 130°F (-18°C to +55°C)
- Max Operating Pressure 7500 psi
- Max Cycle Rate 60 cpm
- Cycle Life Expectancy 10,000,+ cycles
- Part Number 527-001-231

FIELD-SENSITIVE - MAGNETIC (FSmag) PROXIMITY SWITCH FOR HAZARDOUS ENVIRONMENTS (OPTIONAL)

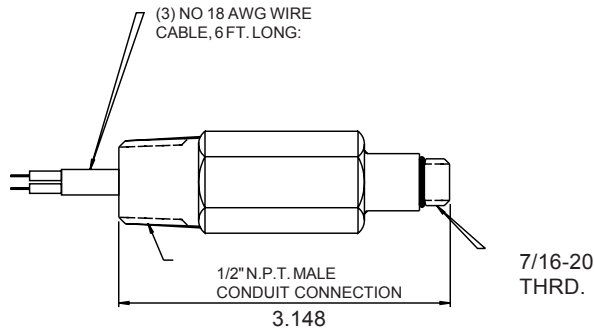

This ceramic-magnet switch is installed in place of a piston enclosure plug and detects the cycling divider valve piston as it moves back and forth.

It can be used with any size MH working section and is suitable for use in systems operating in hazardous environments.

SPECIFICATIONS

- Current Rating 2 AMP @ 120/240 VAC
0.5A @ 125/250 VDC (UL)
0.05A @ 24 VDC (CSA)
- Temperature Range -22°F to 250°F
-30°C to 121°C
- Normally Open Contacts
- Maximum Cycle Rate 200 CPM
- Cycle Life Expectancy 150,000,000 + Minimum Cycles
- Maximum Operating Pressure 3500 PSI

UL & CSA Listed for CL 1. Groups A,B,C, and D. Div. 1, and CL 2. Groups E, F, and G. Div. 1.

Part Number 527-003-431

FIELD-SENSITIVE-MECHANICAL (FSmech) PROXIMITY SWITCH FOR HAZARDOUS ENVIRONMENTS (SUPPLIED AS STANDARD WITH MENU CODE OPTIONS E,F,G,M,N,P)

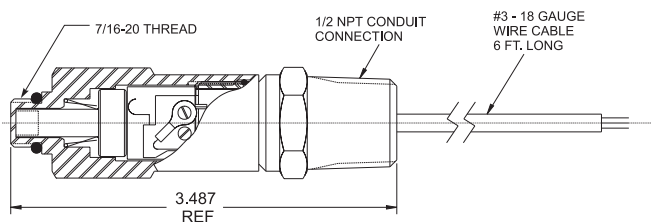

This mechanical switch is installed in place of a piston enclosure plug and is actuated by the movement of the piston.

It can be used with any size MH working section and is suitable for use in systems operating in hazardous environments.

SPECIFICATIONS

- Current Rating 1.2 volt-amps at 28VDC
..... 5 A Resistive, at 115/230 VAC
- Temperature Range -58°F to +167°F
-50°C to +75°C
- Normally Open Contacts
- Maximum Cycle Rate 150 CPM
- Cycle Life Expectancy 10,000,000 +cycles
- Maximum Operating Pressure 7500 PSI
- CSA Certified for CL1. Groups A,B,C and D. Div. 1.
- Part Number 527-006-060

PERFORMANCE INDICATORS

Performance indicators respond to the increase in pressure which occurs when lube lines or lube points become blocked. When installed in indicator ports of working piston sections, they pinpoint blockage location. Some models relieve the excessive pressure, allowing the divider valve to continue to cycle. Some models do not relieve the excessive pressure, causing the divider valve to lock up.

Automatic Reset Relief Indicator



A spring-loaded piston unseats when lube line blockage occurs and lubricant escapes through a vent to the atmosphere. This allows the system to continue lubricating the other unaffected points. When the blockage is cleared, the piston automatically reseats.

Part Number	Relief Pressure
508-310-415	750 PSI (52 bar)
508-310-425	1000 PSI (69 bar)
508-310-435	1250 PSI (86 bar)
508-310-445	1500 PSI (104 bar)
508-310-455	2000 PSI (138 bar)
508-310-465	2500 PSI (173 bar)
508-310-475	3000 PSI (207 bar)

Disc-Type Pressure Indicator



A blow-out disc ruptures when lube line blockage occurs and lubricant forces a pin to protrude from the body of the indicator. There is no provision for relief and the pressure escalates until relieved elsewhere in the system. The disc must be replaced and the pin reset manually after the blockage is eliminated.

Part Number	Relief Pressure
509-499-625	2800 PSI (193 bar)
509-499-105	3700 PSI (255 bar)
509-499-125	4600 PSI (317 bar)
509-499-145	5500 PSI (380 bar)
509-499-165	6400 PSI (441 bar)

Spring-Type Pressure Indicator with Memory



When blockage occurs, a spring-loaded piston unseats and forces a separate indicator pin to protrude from the body of the indicator. There is no provision for relief, and the pressure escalates until relieved elsewhere in the system. The spring automatically reseats the piston but the indicator pin must be reset manually after the blockage is eliminated.

Part Number	Pressure
509-932-590	250 PSI (17 bar)
509-932-600	500 PSI (35 bar)
509-932-610	750 PSI (52 bar)
509-932-620	1000 PSI (69 bar)
509-932-630	1500 PSI (103 bar)
509-932-640	2000 PSI (138 bar)
509-932-650	2500 PSI (173 bar)
509-932-831	3000 PSI (207 bar)
509-932-832	5000 PSI (345 bar)

OUTLET CHECK VALVES

NPT Divider Valve Outlet Check Valves			
Max. Operating Pressure	Cracking Pressure	Description	Part Number
5000 PSI	10 PSI	1/8-27 M X 1/8-27 F NPFT NPSF Carbon Steel Hard Seat	509-350-010
	35 PSI	"	509-350-030
	100 PSI	"	509-350-100
	250 PSI	"	509-350-250
	360 PSI	"	463-001-582
7500 PSI	35-60 PSI	1/8-27 M X 1/4-18 F NPFT NPSF Stainless Steel Soft Seat	463-001-580
SAE Divider Valve Outlet Check Valves			
Max. Operating Pressure	Cracking Pressure	Description	Part Number
3500 PSI	20 -50 PSI	7/16-20 M X 7/16-20 F Stainless Steel Hard Seat	463-001-589
		7/16 - 20 M x 7/16 - 20 F Stainless Steel Soft Seat	463-001-585

Outlet check valves enhance system integrity by ensuring that contaminants, air or gases do not back up into the lubrication system.

DIMENSIONS

Inches/(mm)

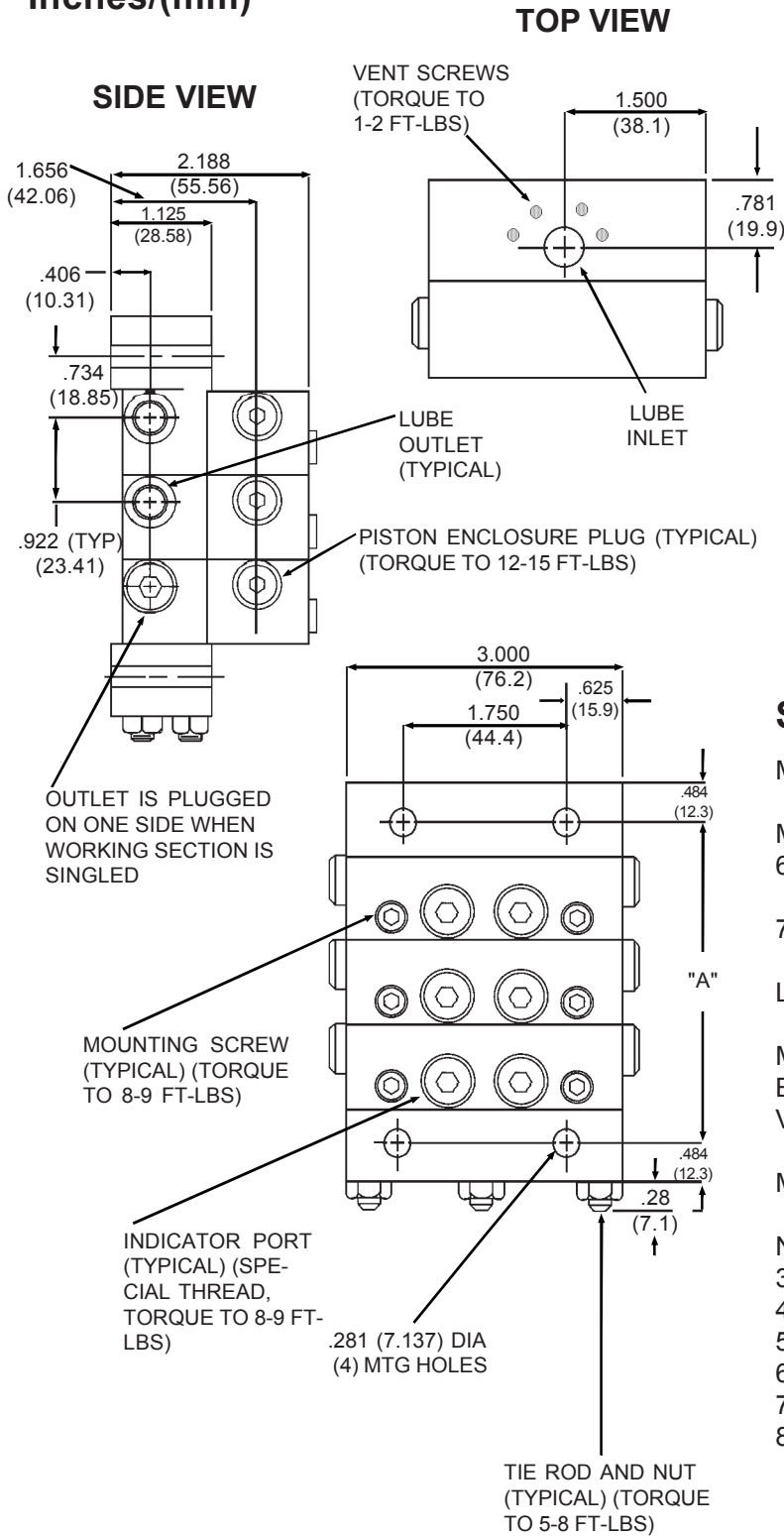

PORT SIZES:

Inlet	Outlet
1/4-18 (F) NPSF	1/8-27 (F) NPSF
7/16-20 (F) SAE	7/16-20 (F) SAE

Qty of Sections	"A"
3	3.578 (90.88)
4	4.500 (114.30)
5	5.422 (137.71)
6	6.344 (161.13)
7	7.266 (184.55)
8	8.188 (207.97)

SPECIFICATIONS

- Material.....Steel Body (Corrosion Protected)
Steel Piston (Honed Fit)
- Maximum Pressure
6,000 psi for Petroleum Oil only
..... Buna O-Rings (422-010-060)
7,500 psi for Petroleum or Synthetic Oil
..... Viton O-Rings (527-000-840)
- Lubricant.....Petroleum or Synthetic Oil only
- Maximum Operating Temperature
Buna-N O-Rings.....200°F (93°C)
Viton O-Rings.....350°F (163°C)
- Maximum Cycle Rate 200 CPM
- Net Weight
3-section divider valve assembly 5.9 lbs (2.7 kg)
4-section divider valve assembly 7.3 lbs (3.3 kg)
5-section divider valve assembly 8.7 lbs (4.0 kg)
6-section divider valve assembly 10.2 lbs (4.6 kg)
7-section divider valve assembly 11.6 lbs (5.6 kg)
8-section divider valve assembly 13.0 lbs (5.9 kg)

ORDERING INFORMATION

MH DIVIDER VALVE ASSEMBLY ORDERING CODE

XXX-XXX- X X-XX X XX

SERIES OF DIVIDER

- MHP - STANDARD COMPRESSOR TO 6,000 PSI (BUNA SEALS)
- MHH - HIGH PRESSURE COMPRESSOR TO 7,500 PSI (VITON SEALS)

INLET - OUTLET THREADS

- NPT - INLET 1/4 -18, OUTLET 1/8 - 27
- SAE - INLET 7/16 - 20, OUTLET 7/16 - 20

DIVIDER VALVE ACCESSORY OPTIONS (OMIT WHEN NOT REQUIRED)

- P - ASSEMBLY OF PERFORMANCE INDICATORS IN ALL WORKING OUTLETS **
- C - ASSEMBLY OF EXTERNAL CHECK VALVES IN ALL WORKING OUTLETS **
- B - ASSEMBLY OF PERFORMANCE INDICATORS & CHECK VALVES IN ALL WORKING OUTLETS **

NUMBER OF SECTIONS

- 3 - THREE
- 4 - FOUR
- 5 - FIVE
- 6 - SIX
- 7 - SEVEN
- 8 - EIGHT

WORKING SECTION CAPACITY

- 06 - .006 CU. IN.
- 09 - .009 CU. IN.
- 12 - .012 CU. IN.
- 18 - .018 CU. IN.
- 24 - .024 CU. IN.
- 30 - .030 CU. IN.
- BP - BYPASS

TYPE OF VALVE SECTION

- T - TWIN VALVE
- S - SINGLE VALVE-RH OUTLET
- L - SINGLE VALVE-LH OUTLET
- B - TWIN VALVE W/CYCLE PIN RIGHT
- C - SINGLE VALVE W/CYCLE PIN RIGHT - RH OUTLET
- D - SINGLE VALVE W/CYCLE PIN RIGHT - LH OUTLET
- E - TWIN VALVE W/PROXIMITY SWITCH RIGHT
- F - SINGLE VALVE W/PROXIMITY SWITCH RIGHT - RH OUTLET
- G - SINGLE VALVE W/PROXIMITY SWITCH RIGHT -LH OUTLET
- H - TWIN W/CYCLE PIN LEFT
- J - SINGLE W/CYCLE PIN LEFT - RH OUTLET
- K - SINGLE W/CYCLE PIN LEFT - LH OUTLET
- M - TWIN W/PROX. SW. LEFT
- N - SINGLE W/PROX. SW. LEFT - RH OUTLET
- P - SINGLE W/PROX. SW. LEFT - LH OUTLET

CROSSPORTING OPTION (OMIT WHEN NOT REQUIRED)

- CR - RIGHT HAND SIDE
- CL - LEFT HAND SIDE
- CB - BOTH SIDES

** PERFORMANCE INDICATOR/CHECK VALVE PART NUMBER MUST BE SPECIFIED ON ORDER.

• SPECIFYING E,F, G, M, N, OR P WILL INCLUDE THE STANDARD FSmech 527-006-060 PROXIMITY SWITCH. CONSULT THE FACTORY IF OTHER PROXIMITY SWITCH OPTIONS ARE RQUIRED.

NOTES:

- 1) RIGHT / LEFT HAND IS DETERMINED WHEN VIEWING FRONT OF DIVIDER VALVE ASSEMBLY WITH INLET AT TOP.
- 2) WORKING SECTIONS ARE SPECIFIED STARTING FROM INLET SECTION DOWN.
- 3) WHEN VALVE IS CROSSPORTED, ITS OUTLET IS PLUGGED AND OUTPUT IS DIVERTED TO NEXT VALVE FARTHEST FROM INLET.
- 4) LAST VALVE IN DIVIDER ASSEMBLY, FARTHEST FROM INLET, CANNOT BE CROSSPORTED.
- 5) WHEN VALVE IS A TWIN, BOTH OUTLETS IN ITS SUBPLATE MUST BE USED. WHEN VALVE IS A SINGLE, ONLY ONE OUTLET IN ITS SUBPLATE CAN BE USED AND THE OTHER OUTLET MUST BE PLUGGED.
- 6) SINGLE VALVE CAN BE CROSSPORTED ON ONE SIDE ONLY.
- 7) CYCLE PINS ARE LIMITED TO APPLICATIONS OF 3,500 PSI MAX.
- 8) CYCLE PINS ARE AVAIL-ABLE ON MH 18,24 & 30 SIZE VALVES ONLY.
- 9) FSmech PROXIMITY SWITCHES CAN BE USED ON ALL SIZES OF MH WORKING SECTIONS.
- 10) ALL DIVIDER VALVE ASSEMBLIES MUST HAVE A MINIMUM OF 3 WORKING SECTIONS AND A MAXIMUM OF 8 WORKING SECTIONS..



Lubriquip endorses the SAE recommendation of ISO 18/14 (ISO 4406) oil cleanliness for most bearing applications. Some high speed bearings may require cleaner oil. Consult the bearing manufacturer for recommendation.

® Registered trademark of LUBRIQUIP, INC.,
A Unit of IDEX Corporation, Printed in U.S.A.