

## DESCRIPTION

Trabon Performance Indicators are pressure-sensitive devices that pinpoint excessive pressure in Trabon series progressive lubricating systems. These devices, which are installed in the alternate outlet ports of divider valves, signal a fault either by causing an indicator pin to protrude or by releasing lubricant to the atmosphere.

All Performance Indicators respond quickly to protect the lube system and locate lube line blockage. Two of these devices—the Reset Indicator with Memory and the Rupture Indicator—will stop lube system operation when a fault occurs. If, however, lube system operation must continue in spite of a single line being blocked, the Automatic Relief Indicator should be used. Rupture-to-Atmosphere Indicators for Trabon pumps are also included.

It is recommended that some type of Performance Indicator be used to monitor every working outlet of a Trabon Centralized Lubrication System.

### Reset Indicator with Memory

Reset Indicators stop lube system operation when a fault occurs. These devices can be used in either master or secondary divider valves. When a lube line becomes blocked, the resultant high pressure moves pistons (A) and (B) (see Figure 1). This movement compresses the spring and pushes indicator pin (C) through the opening in the cap. The high pressure prevents the affected divider valve piston from completing its cycle, causing a pressure backup through the divider valve which trips a pressure switch upstream from the valve and shuts off the pump. As high pressure is relieved, the spring expands, resetting the pistons. Indicator pin (C) is held in place by o-ring (D) until it is reset manually. This helps locate the lube line that is blocked.

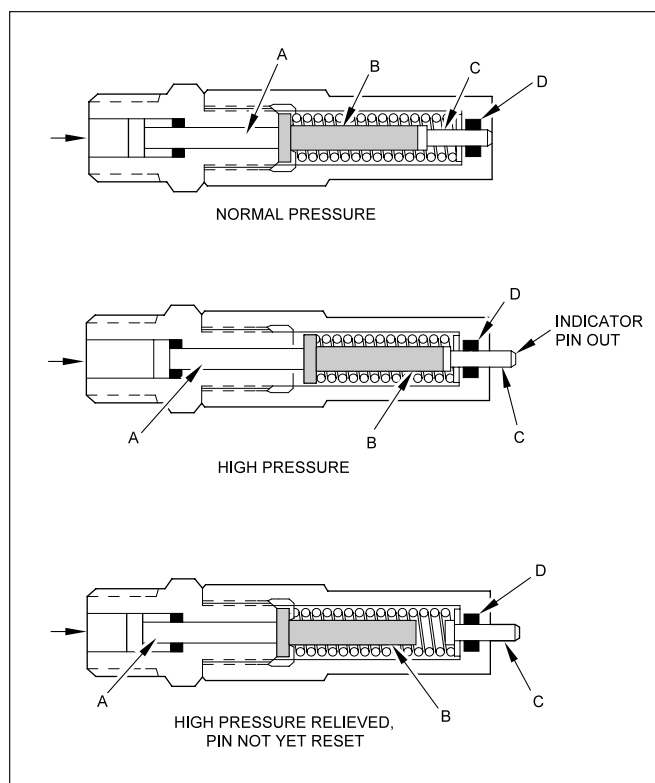

Figure 1. Reset Indicator Operation

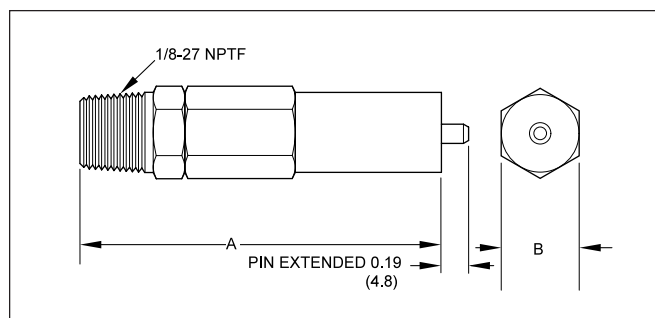

Figure 2. Reset Indicator Dimensions

Pressure (PSI)	1/8" NPTF	1/8" NPSF w/O-Ring	Nickel Plated	1/4" NPTF	7/8"-14 SAE w/O-Ring
	MJ, MH, MS, MXP	MH, MS, MXP	1/8" NPTF	MX only	MGO
			MJ, MH, MS, MXP		
250	509-931-010	509-932-590	509-932-210	509-932-010	509-932-018
500	509-931-020	509-932-600	509-932-220	509-932-020	509-932-028
750	509-931-030	509-932-610	509-932-230	509-932-030	509-932-038
1000	509-931-040	509-932-620	509-932-240	509-932-040	509-932-048
1500	509-931-050	509-932-630	509-932-250	509-932-050	509-932-058
2000	509-931-060	509-932-640	509-932-260	509-932-060	509-932-068
2500	509-931-070	509-932-650	509-932-270	509-932-070	509-932-078
<b>Dimensions (See Figure 2)</b>					
A	2.34 (59.5)	2.44 (62.0)	2.34 (59.5)	2.47 (62.7)	2.63 (66.8)
B	0.50 (12.7)	0.56 (14.3)	0.50 (12.7)	0.56 (14.3)	1.00 (25.4)
O-Ring	NO	YES	NO	NO	YES

Table 1. Reset Indicator with Memory Ordering Data/Dimensions

**Automatic Relief Indicator**

These Performance Indicators pinpoint lube line blockage but allow the lube system to continue to supply lubrication to points that are not blocked. They are used primarily in secondary divider valves. The excessive pressure created by line blockage moves a piston, enabling the lubricant to escape through a vent. (See Figure 3.) When the pressure is relieved, the spring resets the piston. Because these devices permit the lube system to keep operating when a lube point is blocked, a separate pressure switch connected to an audible or visual alarm should be used to warn of high pressure.

Pressure (PSI)	1/8" NPTF MJ, MH, MS, MXP	1/8" NPSF w/O-Ring MH, MS, MXP	1/4" NPTF MX only
750 +20%	508-310-075	508-310-415	508-210-075
1000 +20%	508-310-100	508-310-425	508-210-100
1250 +20%	508-310-125	508-310-435	Not Available
1500 +20%	508-310-150	508-310-445	508-210-150
2000 +20%	508-310-200	508-310-455	508-210-200
2500 +20%	508-310-250	508-310-465	508-210-250
3000 +24%	508-310-300	508-310-475	508-210-300

**Table 2. Automatic Relief Indicators**

Automatic Relief Indicators used to be identified by the color of the spring retainer in the end of the indicator. Pressure ratings are now stamped on the body of the indicator. Table 3 is shown for reference and to aid in the selection of replacement indicators.

Retainer Color	Pressure Rating
Blue	750
Green	1000
Yellow	1400
Red	1800
Orange	2200
Aluminum	2500
Purple	Consult the Factory

**Table 3. Reference Table**

**Note:** If you are replacing indicators that have a pressure rating that is no longer available, it is recommended that you select available indicators with the next higher pressure rating.

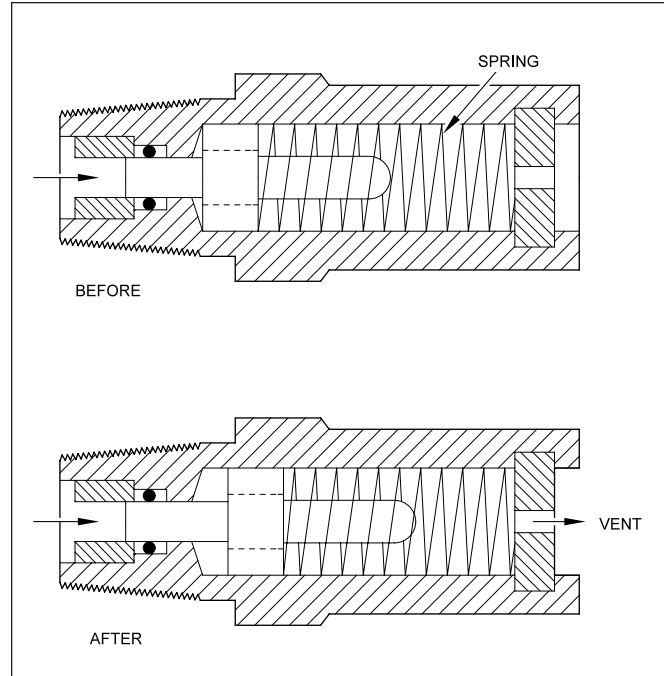

**Figure 3. Automatic Relief Indicator Operation**

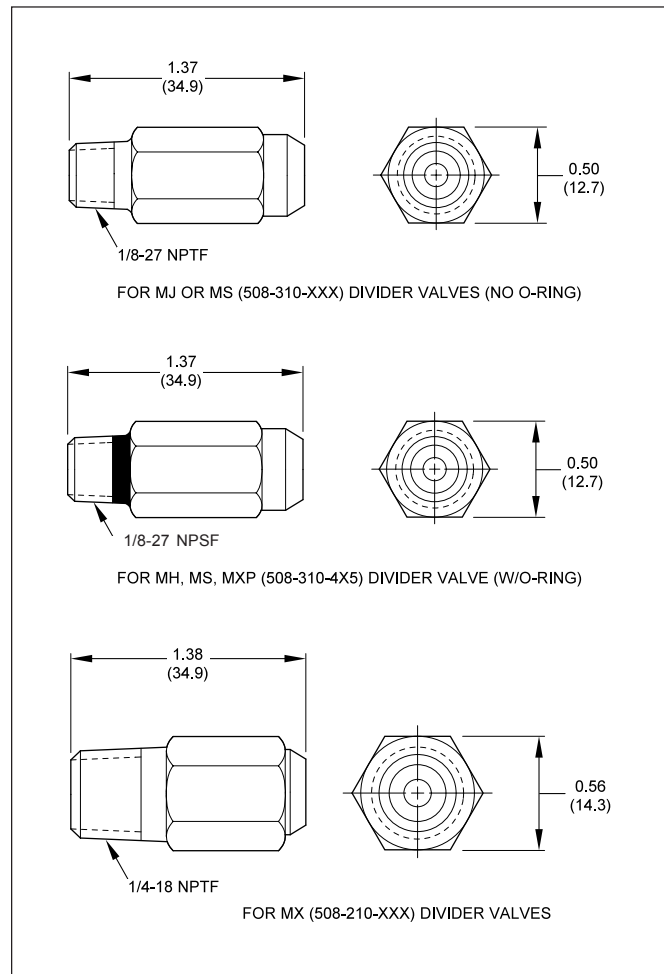

**Figure 4. Automatic Relief Indicator Dimensions**

### Rupture Indicator

Rupture indicators are used on MH divider valve applications where lube system pressures exceed 2,500 psi. The high pressure from lube line blockage causes a disc to rupture. The lubricant then forces an indicator pin to protrude, locating the blockage. (See Figure 5.) The high

pressure backs up through the system and trips a switch to shut the system off. When the fault is corrected, the disc must be replaced and the pin reset manually. See Table 4 for ordering data and Figure 6 for dimensions.

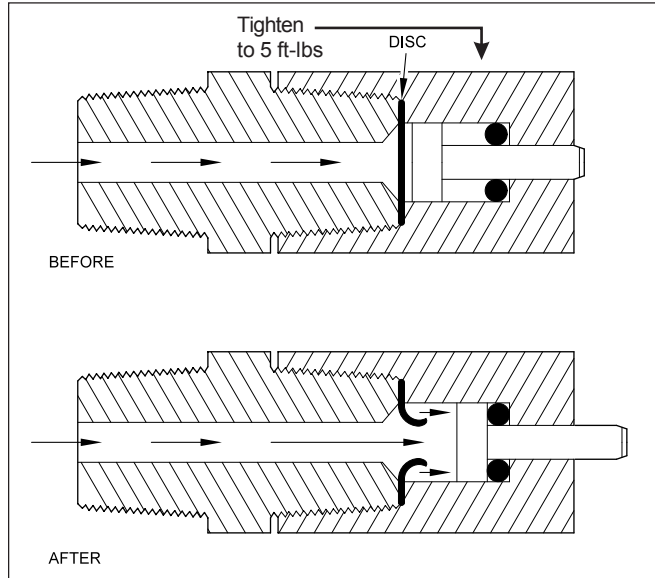

Figure 5. Rupture Indicator Operation

PSI	Complete Assembly		Replacement Disc (3/8" Dia.)	Disc Color
	1/8-27 NPTF	1/8-27 NPSF with o-ring		
2800 +20%	509-499-620	509-499-625	509-277-000	Green
3700 +20%	509-499-100	509-499-105	509-478-000	Half Yellow
4600 +20%	509-499-120	509-499-125	509-479-000	Half Red
5500 +20%	509-499-140	509-499-145	509-480-000	Half Orange
6400 +20%	509-499-160	509-499-165	509-481-000	Aluminum

Table 4. Rupture Indicator Ordering Data

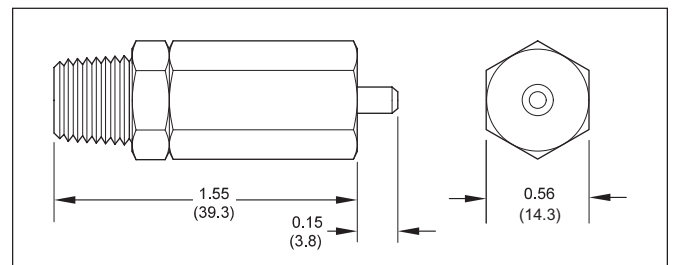

Figure 6. Rupture Indicator Dimensions

### Rupture-to-Atmosphere Indicator

These indicators, which are standard on all Lubriquip pumps, provide pump protection and give visual indication of excessive system pressure. The pressure disc ruptures at a predetermined pressure setting, venting lubricant to the atmosphere and relieving the high pressure. (See Figure 7.) See Table 5 for ordering data.

PSI*	Complete Assembly	Replacement	Disc Color	Blowout Disc
For 1/4" NPTF Fittings		11/16" Dia.		(Qty = 6)
900	509-206-060	509-290-000	Black	560-900-250
1450	509-206-100	509-292-000	Yellow	560-900-270
1750	509-206-120	509-293-000	Red	560-900-280
2050	509-206-140	509-294-000	Orange	560-900-290
2350	509-206-160	509-295-000	Aluminum	560-900-300
2650	509-206-180	509-296-000	Pink	560-900-310
2950	509-206-200	509-297-000	Blue	560-900-320
3250	509-206-220	509-298-000	Purple	560-900-330
For 1/8" NPTF Fittings		3/8" Dia.		(Qty = 25)
900	509-230-060	509-276-000	Black	560-900-050
1450	509-230-100	509-278-000	Yellow	560-900-070
1750	509-230-120	509-279-000	Red	560-900-080
2050	509-230-140	509-280-000	Orange	560-900-090
2350	509-230-160	509-281-000	Aluminum	560-900-100
2650	509-230-180	509-282-000	Pink	560-900-110
2950	509-230-200	509-283-000	Blue	560-900-120
3250	509-230-220	509-284-000	Purple	560-900-130
5000	509-230-350	509-285-200	Brown	560-900-140

\* Discs up to 2350 psi have a tolerance of +500 psi. Discs greater than 2350 psi have a tolerance of +20%.

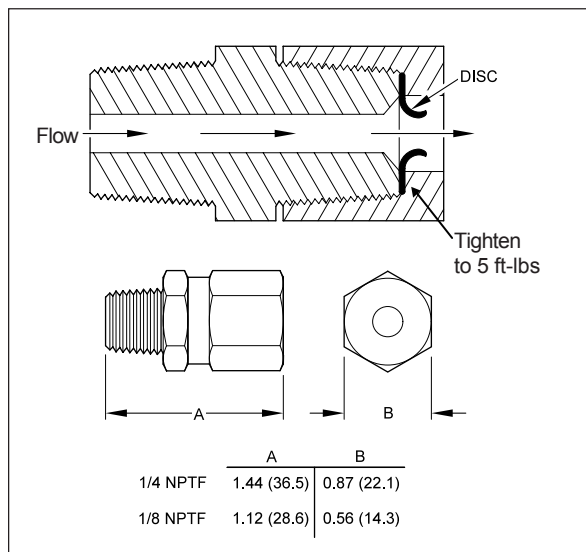

Figure 7. Rupture-to-Atmosphere Indicator Operation/Dimensions

Table 5. Rupture-to-Atmosphere Ordering Data

### Rupture-to-Atmosphere Indicator with Spud Assembly

A spud assembly (see Figure 8) is available to return vented lubricant to the reservoir by way of a tube. See Table 6 for ordering data. A high pressure switch is recommended to provide an audible or visual warning alarm that high system pressure has occurred.

PSI*	Complete Assembly	Replacement Disc (11/16" Dia.)	Color
1450	509-220-101	509-292-000	Yellow
1750	509-220-121	509-293-000	Red
2350	509-220-161	509-295-000	Aluminum

\* All pressures have a tolerance of +500 psi.

**Table 6. Rupture-to-Atmosphere w/Spud Ordering Data**

### Rupture Discs (11/16" Dia.)

The following discs (Table 7) are available (shipped loose). They can be used in either type of Rupture-to-Atmosphere Indicator (509-206-xxx or 509-220-xxx).

PSI*	Disc Part No.	Color
900	509-290-000	Black
1175	509-291-000	Green
1450	509-292-000	Yellow
1750	509-293-000	Red
2050	509-294-000	Orange
2350	509-295-000	Aluminum
2650	509-296-000	Pink
2950	509-297-000	Blue
3250	509-298-000	Purple

\* Discs up to 2350 psi have a tolerance of +500 psi. Discs greater than 2350 psi have a tolerance of +20%.

**Table 7. Rupture Discs**

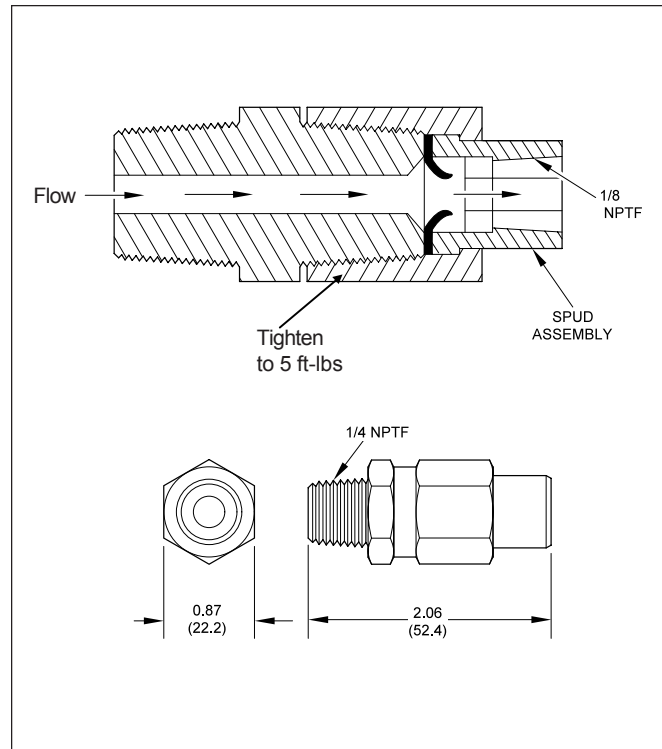

**Figure 8. Rupture-to-Atmosphere w/Spud Assembly**

**Look to LUBRIQUIP, Inc. for all of your Centralized Lubrication System needs.**

**Products include:**

**DIVIDER VALVES:** for oil and grease...to 7500 PSI...1 to 20 points from a single valve assembly...up to 400 points from a Master/Secondaries circuit...or systems that handle an entire plant.

**PUMPS:** fixed and variable displacement...manual and air, hydraulic, electric motor or mechanically driven.

**TIMERS/AUTOMATIC CONTROLS:** from simple on/off to complete flow and pressure monitoring, either time- or machine-actuated.

**ACCESSORY VALVES:** balancing, check and flow.

**INDICATORS:** performance and broken line.

**ACCESSORIES:** fittings, brackets, clamps, filters and strainers.



© Registered trademark of LUBRIQUIP, INC., A Unit of IDEX Corporation, Printed in U.S.A.

